



Directorate of Students' Welfare

Guru Gobind Singh Indraprastha University

Sector-16 C, Dwarka, New Delhi-110078,

Website: <http://ipu.ac.in>, Email id: sports@ipu.ac.in



F. No. GGSIPU/DSW/Sports/2024-25/777

Dated: 11.10.2024

NOTICE

Subject: Schedule and Instruction for participation in 19th Annual Sports Meet-2024 w.r.t. Chess Tournament (Mixed).

19th Annual Sports Meet-2024 Chess Tournament (Mixed) is scheduled from 18th October 2024 to 19th October 2024 in the C-Block, Room No-214.

Procedure for Registration of Teams for participation in Tournament

1. All the teams/participants should report at the venue an hour before scheduled time for the registration and commencement of the match. Late entry will not be entertained.
2. The team shall have to submit eligibility form in the prescribed Proforma (Annexure-I) duly filled and signed by the Principal/Director and photo copy of identity card of all team players at the venue an hour before scheduled time for registration of the team. All columns of the eligibility certificate have to be filled properly.
3. No request for participation shall be entertain without eligibility performa, in any case.
4. The participants should also produce the college identity card, in original at the time of registration / competition or at any time during the tournament.

SCHEDULE

Only one team (gender-neutral) per college is allowed to play. Team size: 4-5 players (4 players play at a time, 1 player as substitute/reserve)

Reporting time — 10 am-12:00 noon (Please ensure you are on time. Once pairings are generated, no new entries will be entertained)

VENUE- C-Block, Room No-214

DAY 1 (18.10.2024)

ROUND 1— [starts at 12:15 PM]

(KNOCKOUT)

1v1 match

TIME CONTROL - 15+5 (15 mins + 5 sec increment on every move) Only one player per team will play in the first round.

[Round 1 must end with decisive results. In case of a draw, 1v1 Armageddon]

Round 2 — [starts at 2 pm] (KNOCKOUT)

TIME CONTROL - 15+5 (15 mins + 5 sec increment on every move)

Time Slot 1- 2:00 pm

Time Slot 2- 3:30 pm

4v4 team match

(Half the teams that qualify after round 1 will play in slot 1 and the other half in slot 2) [Round 2 must have decisive results. In case of a draw, 1v1 Armageddon]

DAY 2 (19.10.2024) [swiss starts at 10:00 am]

ROUNDS 3, 4, 5, 6 and 7 will be a SWISS TOURNAMENT of the remaining teams. Time control- 15+5
4v4 team match

DAY 3 (20.10.2024)

RESERVE DAY + PRIZE DISTRIBUTION (Top 3)

TOURNAMENT RULES :

- Time format: 15 mins + 5 secs increment. (LiChess app clocks will be used, kindly download the LiChess app)
- Tournament Format: Knockouts (Round 1 and Round 2) and remaining Swiss (Round 3, 4, 5, 6 and 7).
- Illegal Moves: First Illegal - Warning. Second Illegal - Forfeiture.
- Fair Play: Players who are detected cheating will be immediately removed from the tournament.
- A master board order should be provided by each team half an hour before the second round. In case of substitution, the players should duly slide up the board in order with the substitute playing at board 4.
- In case of a dispute, any violation of the rules, or any irregularity (illegal move, illegal position), players should stop the clock and raise their hand to notify an arbiter immediately. Do not make another move. Also, do not wait for the game to end to make a claim. Once the game continues, most claims are invalid.
- In all situations, the decision of the arbiter will be final.
- Players are requested to bring their own pens. Writing notation (moves) is not mandatory.
- Standard FIDE rules will be followed.
- Referee/Umpire decision will be FINAL and will be binding to all.
- All participants should follow the Rules & Regulations for Participation in 19th Annual Sports Meet of the University for the Academic Year 2024-25 notified vide notice F. No. GGSIPU/DSW/Sports/2024-25 dated 26.09.2024 Copy of the said notice is available on the University's website under the link at Students' Welfare- Sports and General Notices and Circulars

Vandana
(Prof. Vandana Singh)
Associate Director (SW)

Copy to:

1. All Directors/ Principals of the affiliated Institutes of the University.
2. Assistant Registrar to Vice Chancellor - for kind information of the Hon'ble Vice Chancellor.
3. AR to Registrar for kind information of the Registrar.
4. Deputy Registrar (Estate), GGSIPU
5. Medical Officer with a request for necessary arrangement of First Aid, Ambulance.
6. University Coach
7. In-charge server room – Please upload the notice on the University website on sports link and General Notices/Circular.
8. Guard file.

Surinder Singh
(Surinder Singh)
Section Officer (SW)

Sno.	Round 1
1	AIMT
2	BCIHMCT
3	AIE
4	COMM-IT
5	BCIIT
6	CPJCHS & SOL
7	AIRSR
8	DIAS
9	VIPS TC
10	MAIMS
11	BVCOE
12	BYE
13	DBIT
14	DME
15	FIMT
16	GIBS
17	MAIT
18	BVICAM
19	ADGIPS
20	BYE

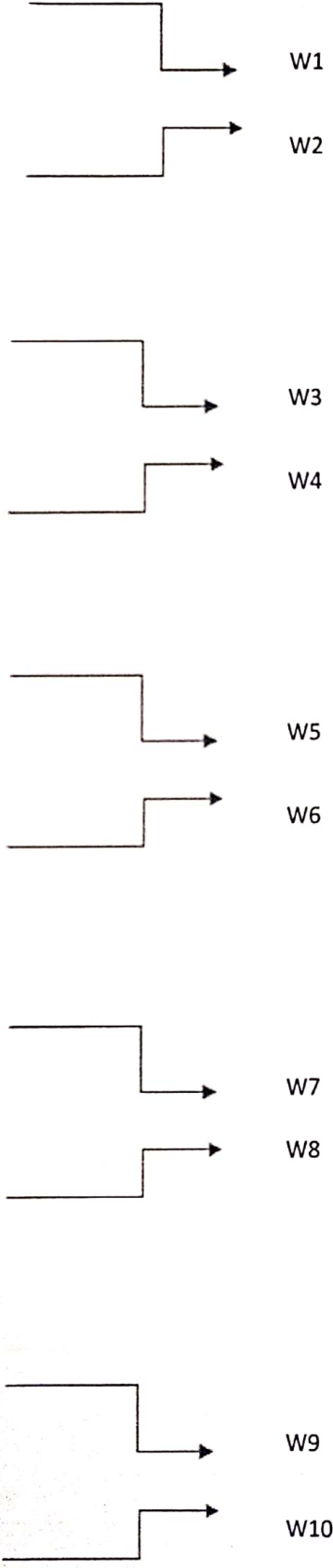

Prasanth

21	GNIT		
22	GTB4CEC	→	W11
23	HMR	→	W12
24	IINTM		
25	USS DWARKA		
26	BYE	→	W13
27	UCE	→	W14
28	C-DAC		
29	BCIP		
30	BLMCE	→	W15
31	DSPSR	→	W16
32	DTC		
33	BCIPS		
34	CBPACS	→	W17
35	IIMT	→	W18
36	IITM		
37	MSIT		
38	NDIM	→	W19
39	KCC	→	W20
40	MBS SPA		

Present

41	USS EDC	┌───┐ └───┘	W21
42	BYE		
43	BVBC	┌───┐ └───┘	W22
44	SCERT		
45	TIAS	┌───┐ └───┘	W23
46	SGTBIMIT		
47	GIAS	┌───┐ └───┘	W24
48	VKA		
49	BPIT	┌───┐ └───┘	W25
50	BYE		
51	MSI	┌───┐ └───┘	W26
52	TIIPS		
53	GTBIT	┌───┐ └───┘	W27
54	ISICIRS		
55	JIMS EMTC	┌───┐ └───┘	W28
56	KIHEAT		
57	KIRAS	┌───┐ └───┘	W29
58	KRCHE		
59	JIMS VK	┌───┐ └───┘	W30
60	MDNIY		

Handwritten signature

61	LLDIMS
62	MERI
63	JIMS, KALKAJI
64	RDIAS
65	SIMS
66	SSHCON
67	Trinity Dwarka
68	JIMS-R

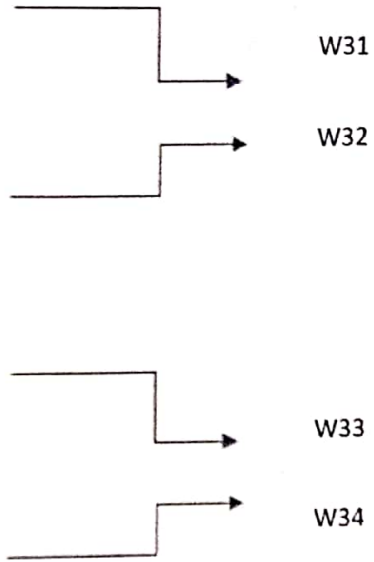

Prabhat



Annexure-1
Directorate of Students' Welfare
Guru Gobind Singh Indraprastha University
A State University established by the Govt of NCT of Delhi
Sector-16 C, Dwarka, New Delhi-110078,
Email: sports@ipu.ac.in
ELIGIBILITY PROFORMA FOR 19th Annual Sports Meet-2024



Name of the Game: _____

Section Men/Women: _____

Name of the Manager/Coach: _____

Name of the participating institute: _____

Contact No. Manager/Coach _____

ACADEMIC YEAR: 2024-25

S. No.	Full Name of Student	Enrollment No.	Programme in which studying	Date of Birth	Present Semester	Mobile No
1.	1	2	3	4	5	6
2.						
3.						
4.						
5.						
6.						
7.						
8.						
9.						
10.						

If numbers of participants are more than 10, please use a copy of this form.

Certified that the above particulars are true as per records of the College / Institute

Seal of College / Institute _____

Signature of the Director / Principal _____